

尺寸: 125X82.5mm

材质: 105g铜版纸

装订方式: 骑马钉装订

红色文字不参与印刷

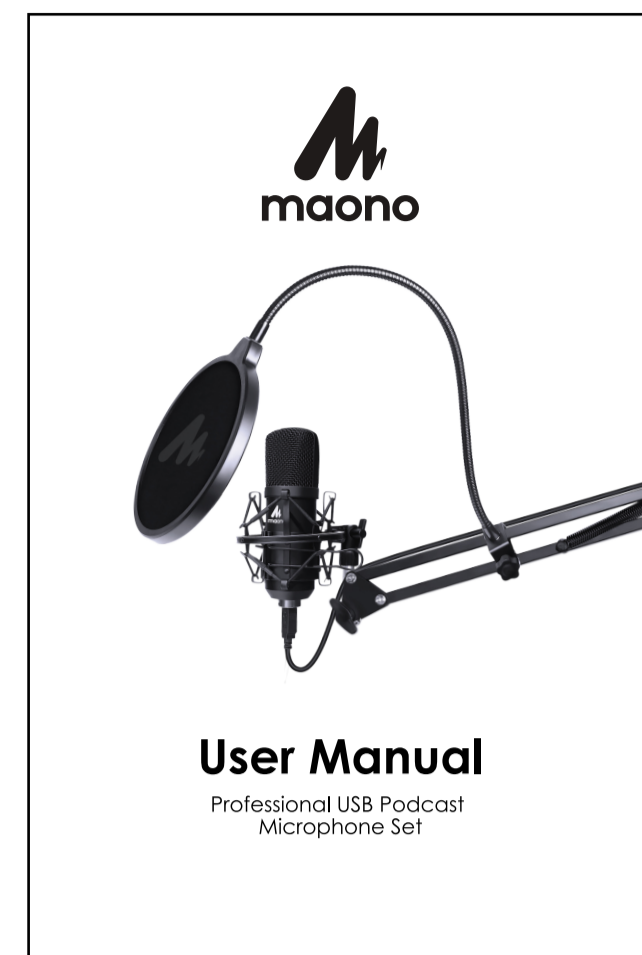

CONTENTS table listing languages and page numbers: English (01-08), Deutsch (09-16), 日本語 (17-23), 中文 (24-31).

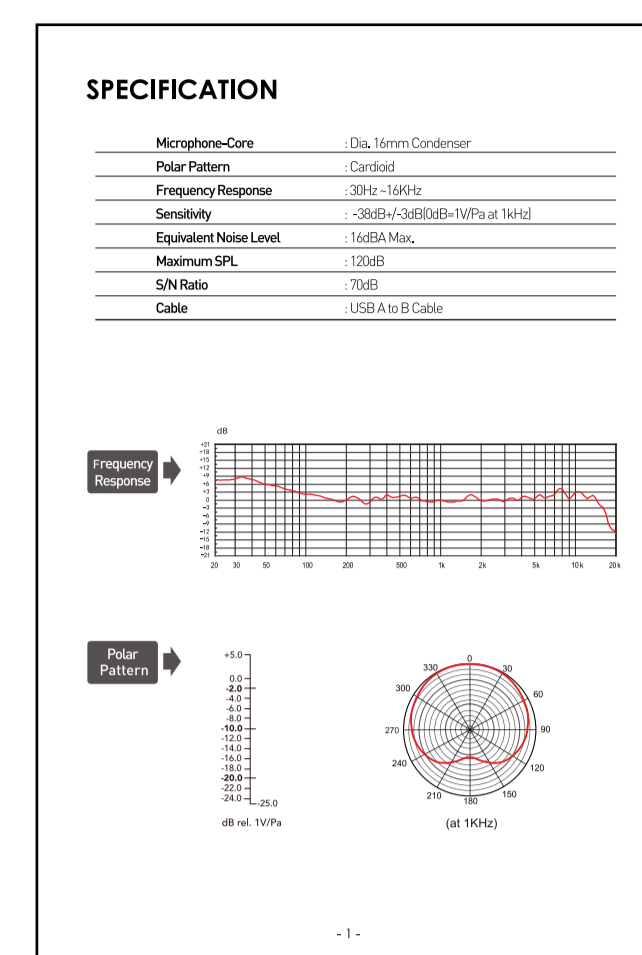

Features section describing the microphone's characteristics, including the capsule, boom arm, and shock mount.

Recording vocals section providing tips on microphone placement and recording techniques for vocals.

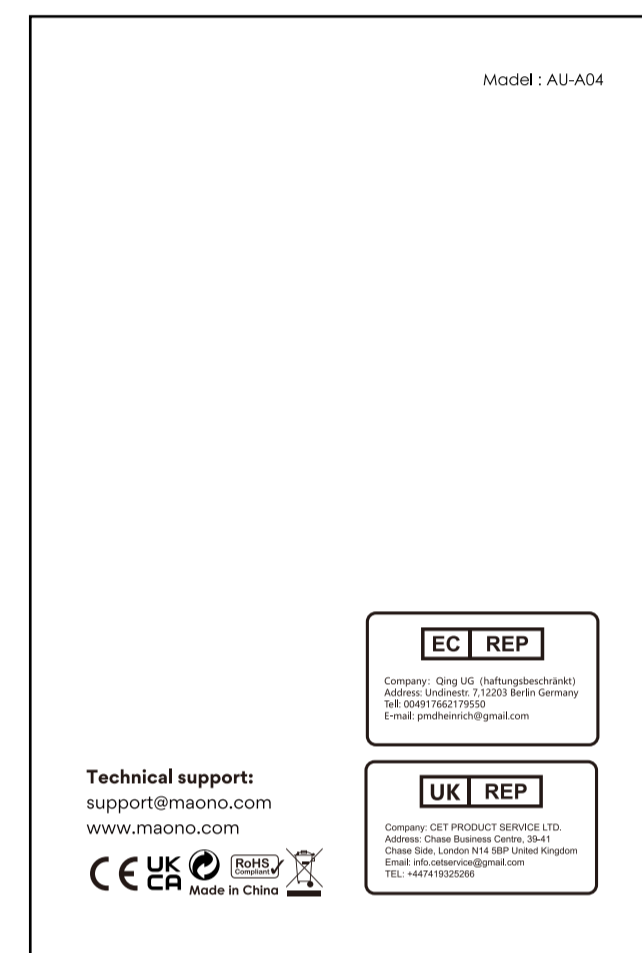
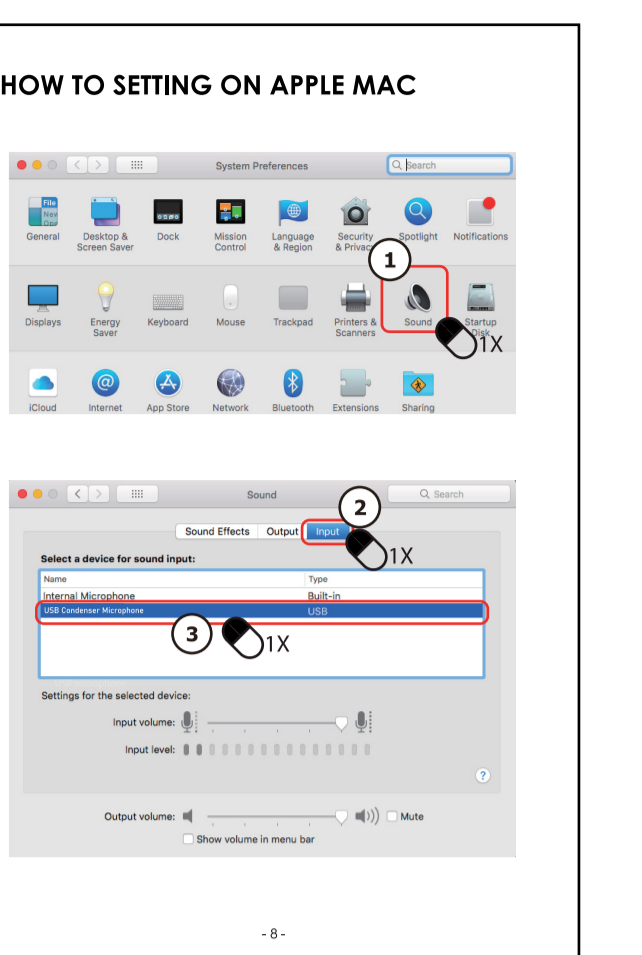
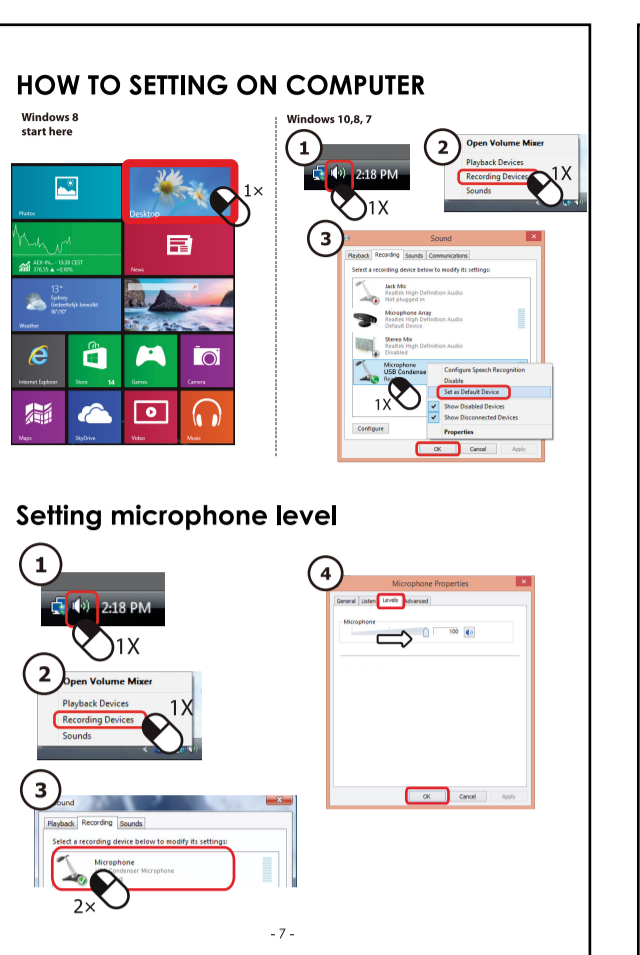
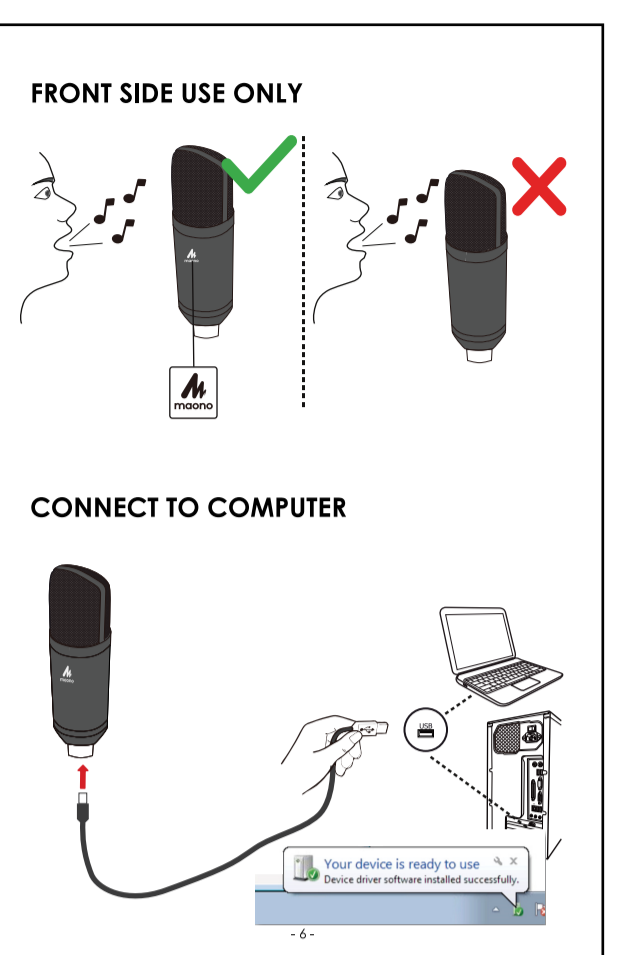
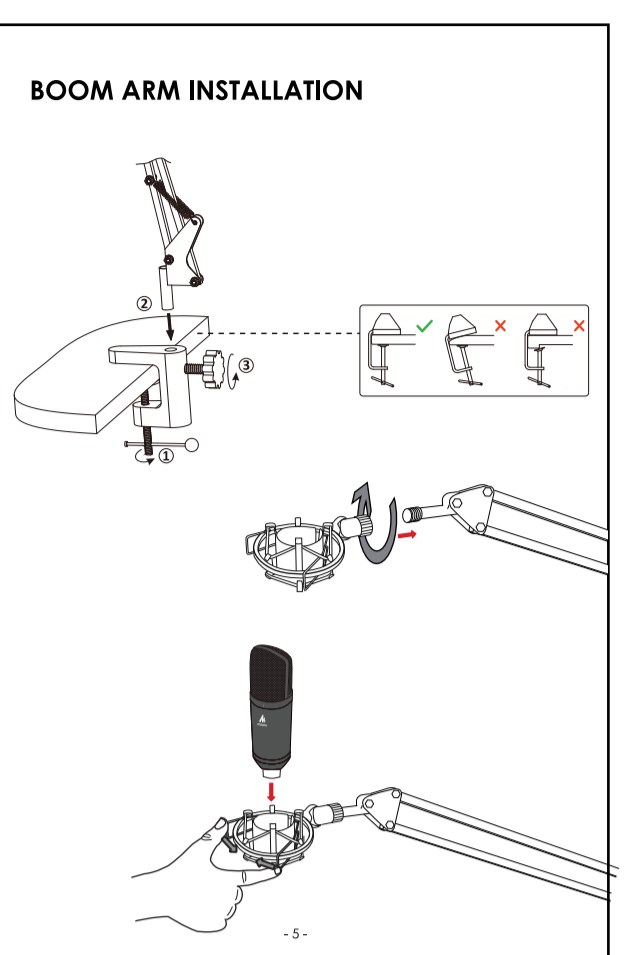
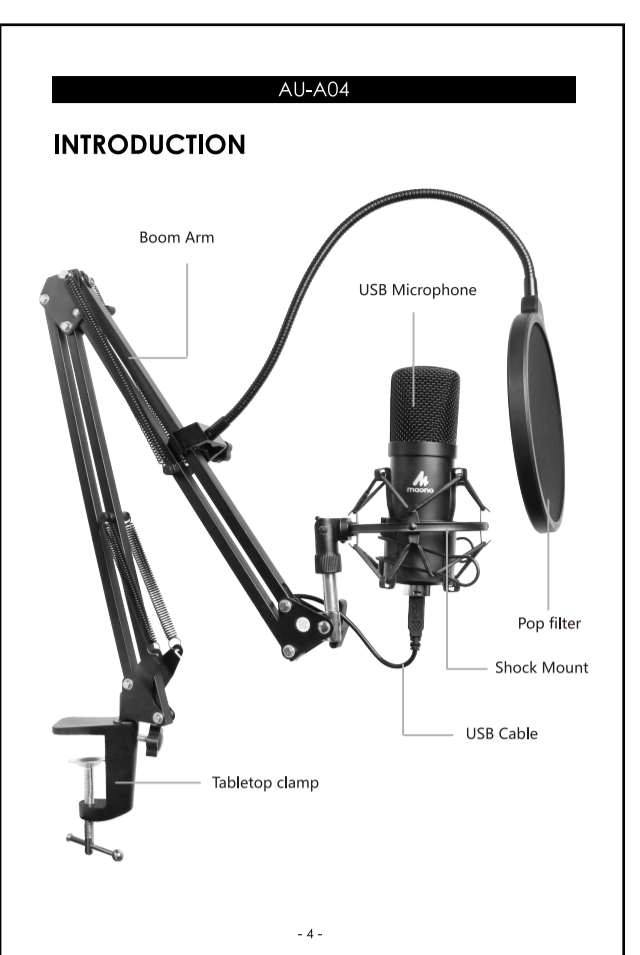

CONTENTS table for the technical manual, listing languages and page numbers.

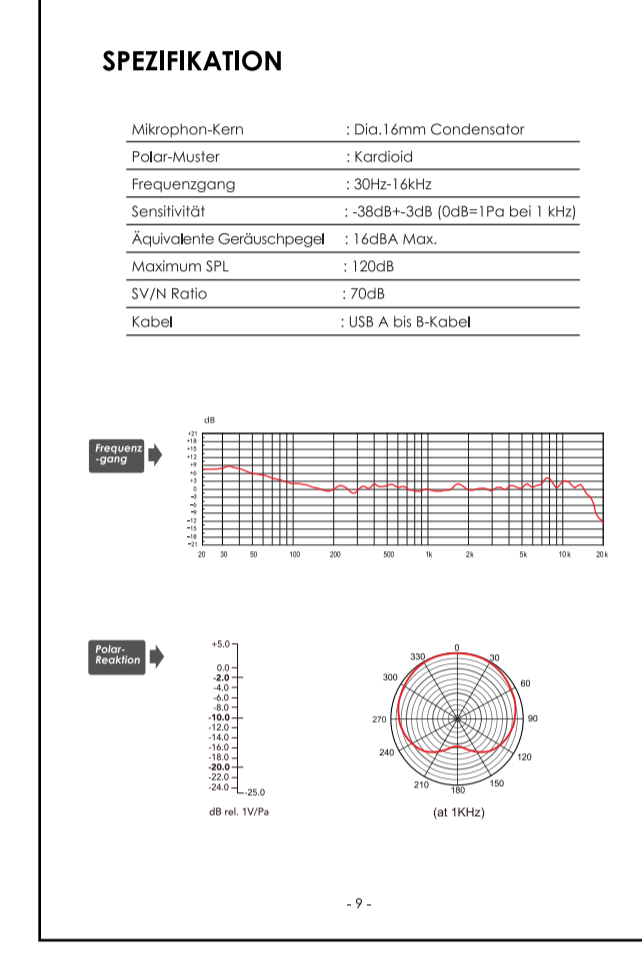

Eigenschaften section describing the microphone's features and characteristics.

Gesang aufnehmen section providing tips on recording vocals and microphone placement.

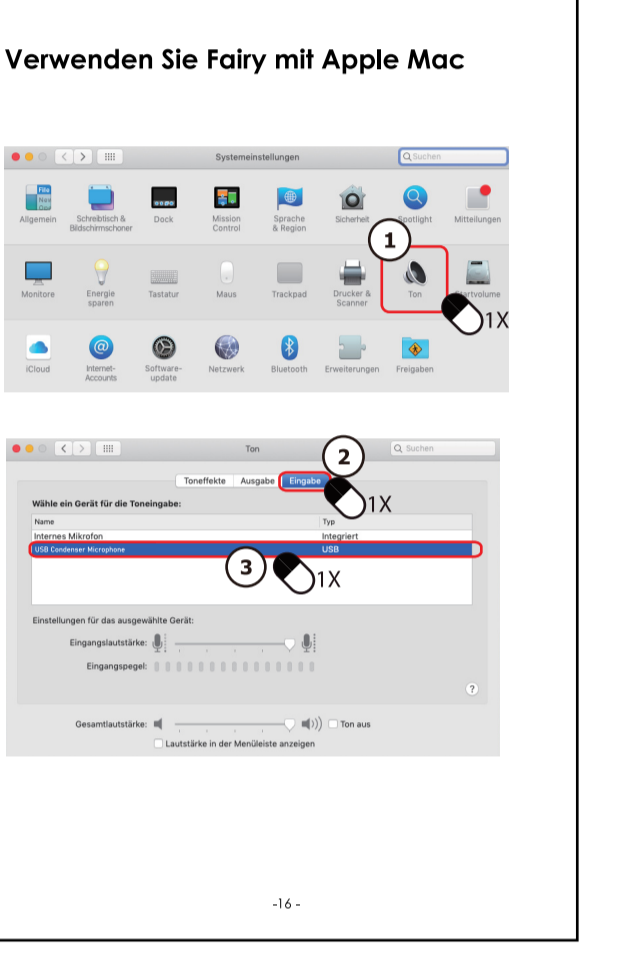
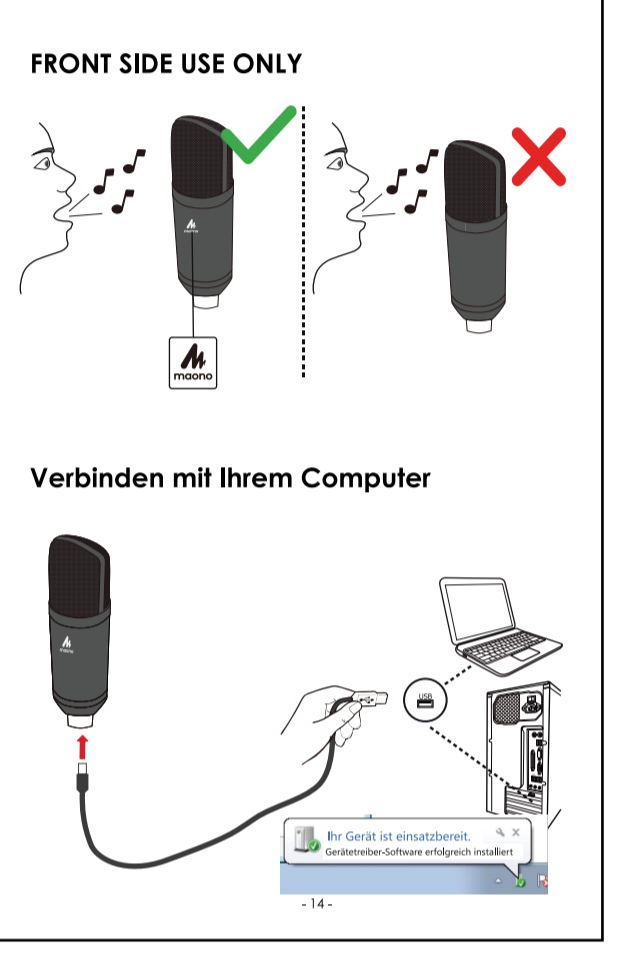
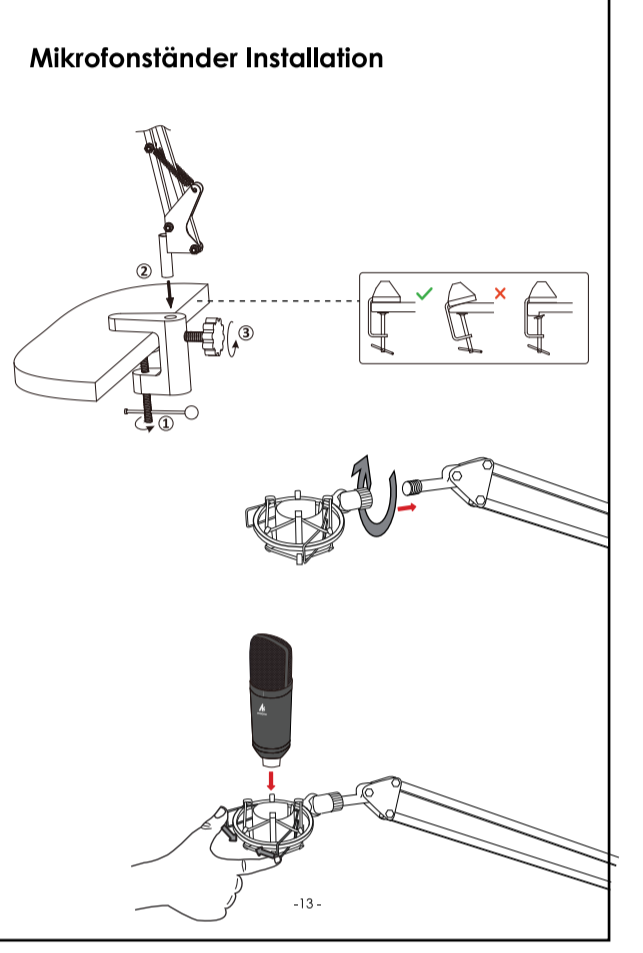
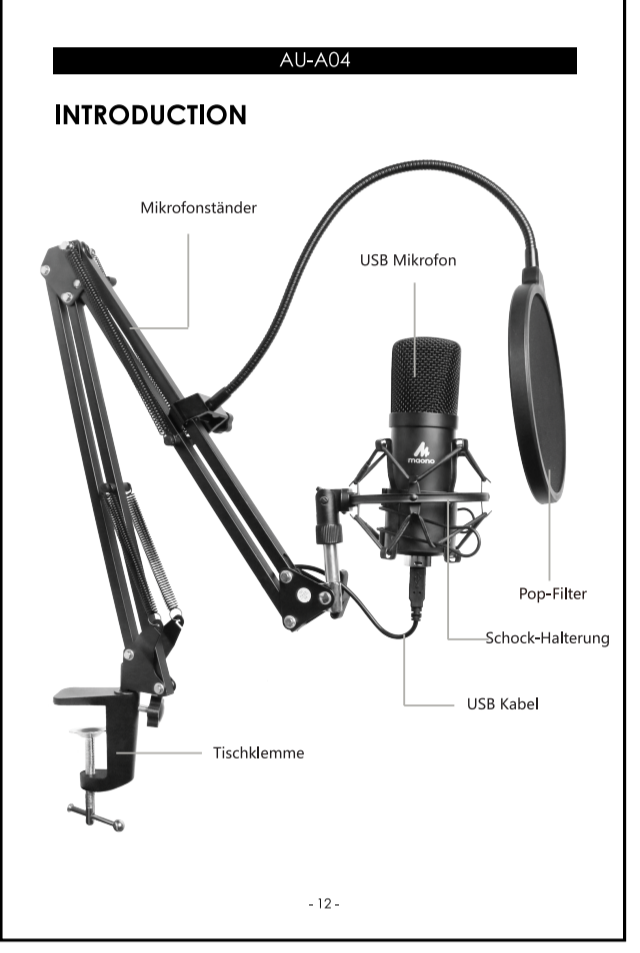

商品仕様 (Product Specifications) table listing technical details like microphone type, frequency response, and dimensions.

特徴 (Features) section describing the microphone's design and performance.

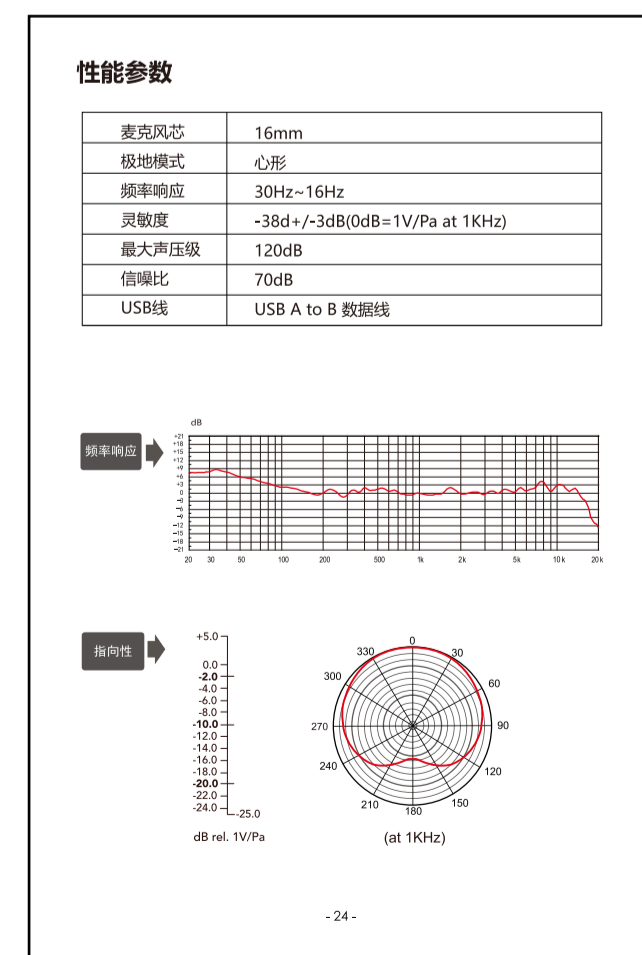
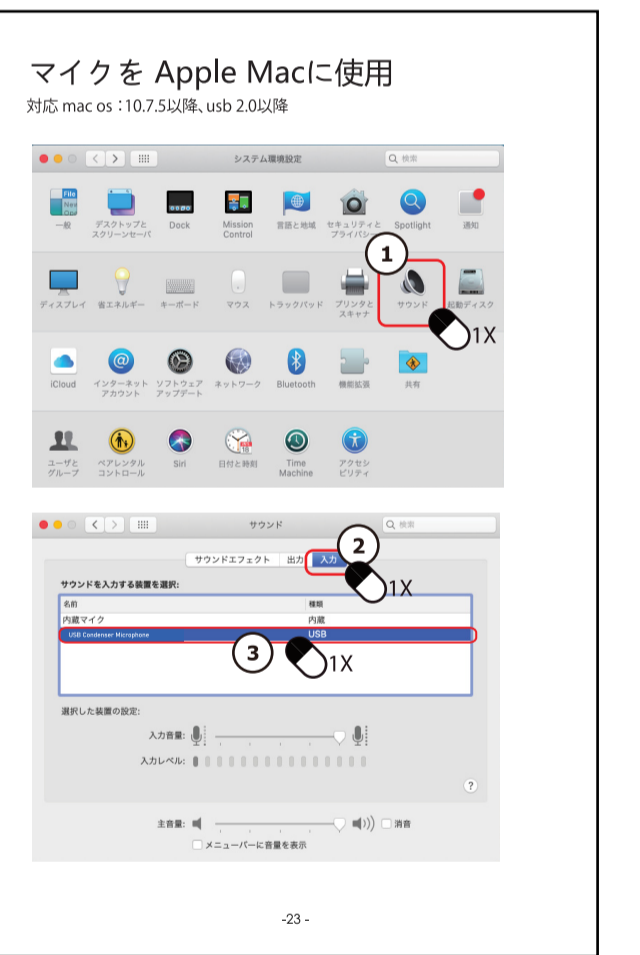
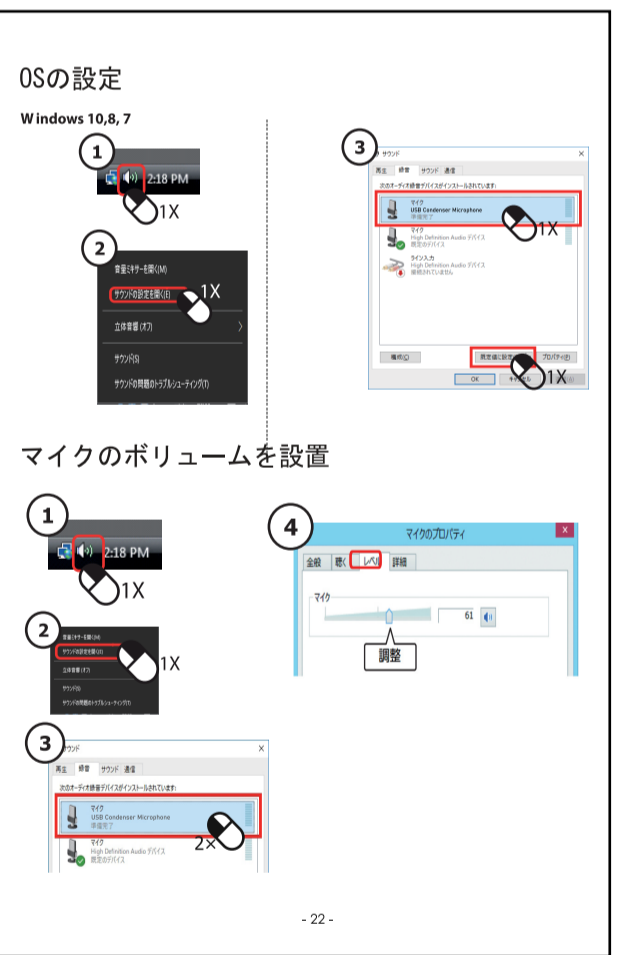
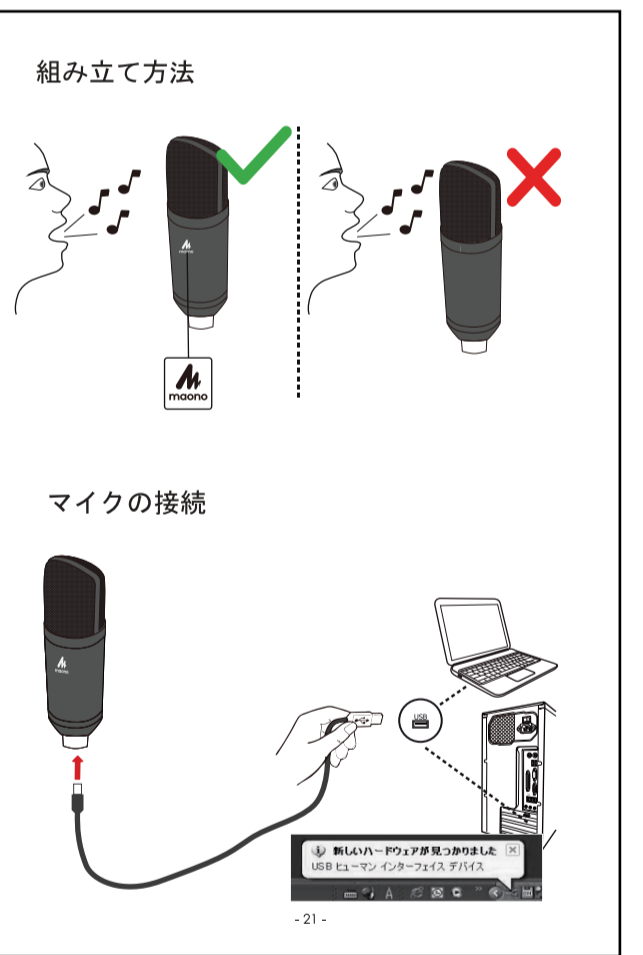
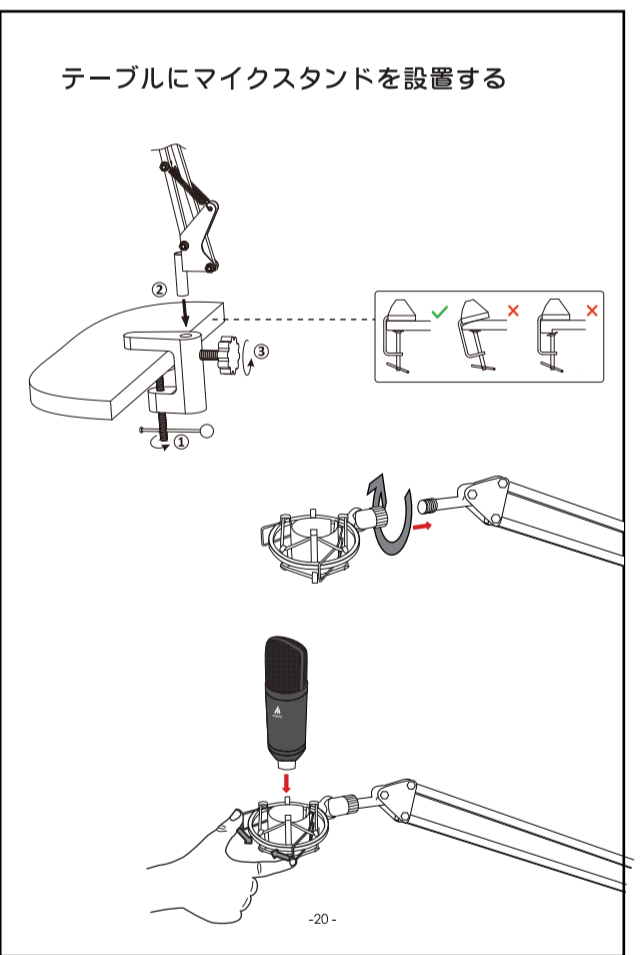

特征 (Features) section describing the microphone's design and performance.

注意事项 (Precautions) section providing safety and usage instructions.

